

## **Placement And Sizing of Renewable Energy Sources Using Improve Wind Driven Optimization (IWDO) Algorithm to Solve Power and Voltage Profile Problems Considering IEEE 30 Bus Network**

**Mamman, Hassan Jatau**  
hassanmammanj@yahoo.com  
08038521435, 08028623692

**Jamous, Chimen Sabo**  
csabotoro@gmail.com  
08033664361

Department Of Technical Education Kaduna State College of Education Gidan Waya.

THE FIRST INTERNATIONAL CONFERENCE ON ATMOSPHERIC, EARTH AND SPACE  
SCIENCES 'ICAESS' LOKOJA KOGI STATE  
22<sup>nd</sup>-25<sup>th</sup> SEPTEMBER, 2024

### **ORGANIZED BY:**

CENTRE FOR ATMOSPHERIC RESEARCH, AYINGBA, KOGI STATE  
IN COLLABORATION WITH FEDERAL UNIVERSITY LOKOJA, KOGI STATE  
DOI:10.56201/ijemt.v10.no9.2024.pg73.82

---

### **Abstract**

*The placement and sizing of renewable energy sources is crucial in solving power and voltage profile problems in the Nigeria power industries. The transmission lines of power systems are more severely loaded than ever before. Hence, the power system is facing many problems such as line overloading, power losses and voltage profile deviation etc. The optimization of real and reactive powers due to the installation of renewable energy sources at the appropriate buses can help to minimize real, reactive power losses and voltage profile deviation. As a result, the deployment of renewable energy sources using improve wind driven optimization algorithm on power network will be considered to mitigate power quality problems. The research work uses Improve Wind Driven Optimization Algorithm to effectively solve power issues in MATLAB software environment. Wind Driven optimization Algorithm is considered for validation purposes. Wind Driven Optimization is a global optimization technique based on atmospheric motion and is a population based iterative heuristic global optimization technique with the ability to apply constraints on search domain for multi-dimensional and multi-modal issues. Therefore, this research aim to bridge the gap by employing IWDO algorithm to solve power quality problems using integrated renewable energy sources. Upon applying the Improved Wind Optimization (IWDO) on the IEEE 30-bus system, there was a reduction in the size of distributed generation (DG) used, 61.25% reduction in real power loss and 57.02% reduction in reactive power loss. The incorporation of renewable energy sources in the optimal power flow problem is crucial for*

*reducing power loss and improving the stability and reliability of power systems thereby contributing to the advancement of sustainable and efficient electricity distribution system.*

**Key words:** *Renewable Energy, Power Flow, Optimization algorithm, Energy, Power systems, Atmosphere,*

---

## **Introduction**

The optimal power flow (OPF) is usually employed to optimize the cost of generation, reducing emissions, minimizing power loss along the transmission lines and ensuring that the voltage remains within stable limits. In carrying out this optimization process, the technical constraints of the power system must be satisfied (Boucekara *et.al.*, 2016). Ignoring these constraints can present challenging situations especially in large power systems. Thus, special care must be taken to ensure that these constraints are not violated. To understand OPF, let's think about an electrical grid like a transportation network. Just like cars need fuel to move, power systems require electricity to operate. OPF helps reduce operating costs, reduce power losses, improve system stability, and enable the integration of renewable energy sources. OPF plays a crucial role in the electrical grid management and decision-making processes, ensuring a reliable and sustainable supply of electricity to consumers (Chamanbaz *et.al.*, 2017). Traditional techniques of resolving OPFs only use traditional sources that burn fossil fuels. With the increased penetration of renewable energy sources (RES) in the power system, it has become necessary to incorporate the uncertain character of these sources into the OPF problem due to challenges during the planning and operational phases. Many traditional ways for overcoming this problem have been presented since the inception of OPF (Farhat *et. al.*, 2021).

The formulation of the optimal power flow problem is critical for planning and operating of electrical power networks. OPF is employed to solve power quality issues such as power losses and voltage profile problems as earlier stated. The power flow embodies the generation, transmission and distribution network and loads. The optimal power flow is a hybrid of power flow (Reddy *et.al.*, 2014). As a result, the OPF is critical for the harmless and profitable operation of the electrical power system by appropriately setting control parameters such as voltages, active power of generator buses, transformer tap settings, and so on. The OPF's main goal is to improve (minimize or maximize) a certain target (voltage stability, power loss, etc.) while meeting equality, inequality, and security requirements. The equality constraints include the power balancing equation, whereas the inequality constraints include voltage, maximum and minimum reactive and real power restrictions, and transmission line capacity (Khamees *et.al.*, 2017).

The desire to lower gas emissions, lower fuel costs, and boost efficiency has led to an increase in the usage of Renewable Energy Sources (RES) in the electrical power system. The electricity market is directly impacted by RES like wind and solar systems, which also reduce line losses, the cost of generating energy, and increase the stability and reliability of the power system (Shaheen *et.al.*, 2022). Additionally, the effectiveness of power network control and operation is significantly impacted by the location of the RES in the grid. The duty of appropriately sizing and placing the RES at an appropriate location on the electricity system falls on the network operators as a result.

### Concept of Wind Driven Optimization Algorithm

A global optimization technique based on atmospheric motion is called the wind driven optimization (WDO) algorithm. Zikri Bayraktar created it at Pennsylvania State University. The WDO is a population-based iterative heuristic global optimization technique with the ability to apply constraints on the search domain for multi-dimensional and multi-modal issues. Fundamentally, a population of infinitely tiny particles moves through an N-dimensional search space in accordance with Newton's second rule of motion, which describes how air molecules move through the earth's atmosphere (Bayraktar *et.al.*, 2010) . When compared to previous particle-based techniques, WDO uses more terms in the velocity update equation, giving the optimization more robustness and degrees of freedom. Based on the idea that wind moves from high-pressure locations to low-pressure areas until there is pressure equilibrium, the wind-driven optimization method was created (Zhou *et.al.*, 2015).

### Improved Wind Driven Optimization

As stated in WDO, until pressure equilibrium is reached, the air molecules are constantly migrating from a location of high pressure to a point of low pressure. It means that if an outside force acts on air particles in equilibrium, they begin to travel. After that, a disturbance is added to prevent early convergence (Liu *et.al.*, 2021). When the air particles hunt for the optimal solution in N-dimensional space and are stuck in local optima, a random dimension  $t$  ( $0 < t < N$ ) is chosen to be distributed and an arbitrary number  $m$  ( $0 < m < 1$ ) which will obey the uniform distribution to make a small disruption in the speed of the 1<sup>st</sup> dimension as seen in Equation (1),

$$u_{i,t}^{p+1} = (2m - 1) \cdot \varepsilon \quad \dots (1)$$

Where

$u$ =velocity of air particles

$m$ = random number between 0 and 1, exclusive

$\varepsilon$ = degree of speed disturbance

$\varepsilon$  is a dynamic number changing with iteration number. As the iteration number increases, the air particles are closer to the optimal solution. Thus with an increase in iteration number, there is a decrease in the disturbance. The value of  $\varepsilon$  can be obtained using Equation (2)

$$\varepsilon = \frac{1}{p^{0.25}} \quad \dots (2)$$

### MATERIALS AND METHODS

The materials needed to carry out the best power flow optimization in order to reduce real, reactive power losses and improve the voltage profile of IEEE 33 bus radial distribution is outlined here.

1. MATLAB (with Optimization Toolbox and Power System Toolbox): This is a powerful tool for numerical computation, data analysis, and visualization, making it an essential platform for various applications.
2. Python (with libraries like Pandas, NumPy, SciPy, and PyPower)
3. Power system simulation software (e.g., OpenDSS, PSS/E, or ETAP)
4. Optimization algorithms (e.g., GA, PSO, or DE). For the purpose of this paper, the MATLAB is implored.

### Objective Function

The objective functions of this research work are basically minimization functions as seen in Equation (3)

The objective function problem formulation can be written as seen in equations below

$$\text{Min}(J) = (P_{total\ losses} + V_D) \quad \dots (3)$$

$$P_T = \sum_{i=1}^{ND} P_{Di} + P_L \quad \dots (4)$$

$$Q_T = \sum_{i=1}^{ND} Q_{Di} + Q_L \quad \dots (5)$$

$$V_D = \sum_i^{NB} \left( \frac{V_{ref} - V_i}{V_{ref}} \right)^2 \quad \dots (6)$$

where  $P_T$  and  $Q_T$  are the total real and reactive power,  $P_{Di}$  and  $Q_{Di}$  are the real and reactive power demand at bus  $i$ ,  $P_L$  and  $Q_L$  are the real and reactive power losses,  $V_D$  is the voltage deviation,  $V_{ref}$  and  $V_i$  are the reference and voltage at bus  $i$  respectively. The constraints are given in equations (5), (6), and (7).

$$V_{min} \leq V_i \leq V_{max} \quad \dots (7)$$

$$Q_{min} \leq Q_i \leq Q_{max} \quad \dots (8)$$

$$P_{min} \leq P_i \leq P_{max} \quad \dots (9)$$

where  $V_i$  is the voltage at bus  $i$  and  $V_{min}$  and  $V_{max}$  are minimum and maximum voltage,  $Q_i$  is the reactive power at bus  $i$  and  $Q_{min}$  and  $Q_{max}$  are minimum and maximum reactive powers and  $P_i$  is the real power at bus  $i$  and  $P_{min}$  and  $P_{max}$  are minimum and maximum real powers.

### The IEEE-30 bus network

The IEEE-30 bus test system was used to run the OPF simulation. The overall active and reactive loads for this test bus system are 283.4MW and 126.2MVAR, respectively. The IEEE-30 bus network has renewable energy incorporated at buses 5 (wind turbine) and 13 (solar photovoltaic) as shown in figure 1 while buses 1, 2, 8 and 11 have non-renewable energy sources (thermal generators) connected to them (Riaz *et.al.*, 2021). Figure 1 below is a pictorial representation of the adopted IEEE-30 bus power system network.

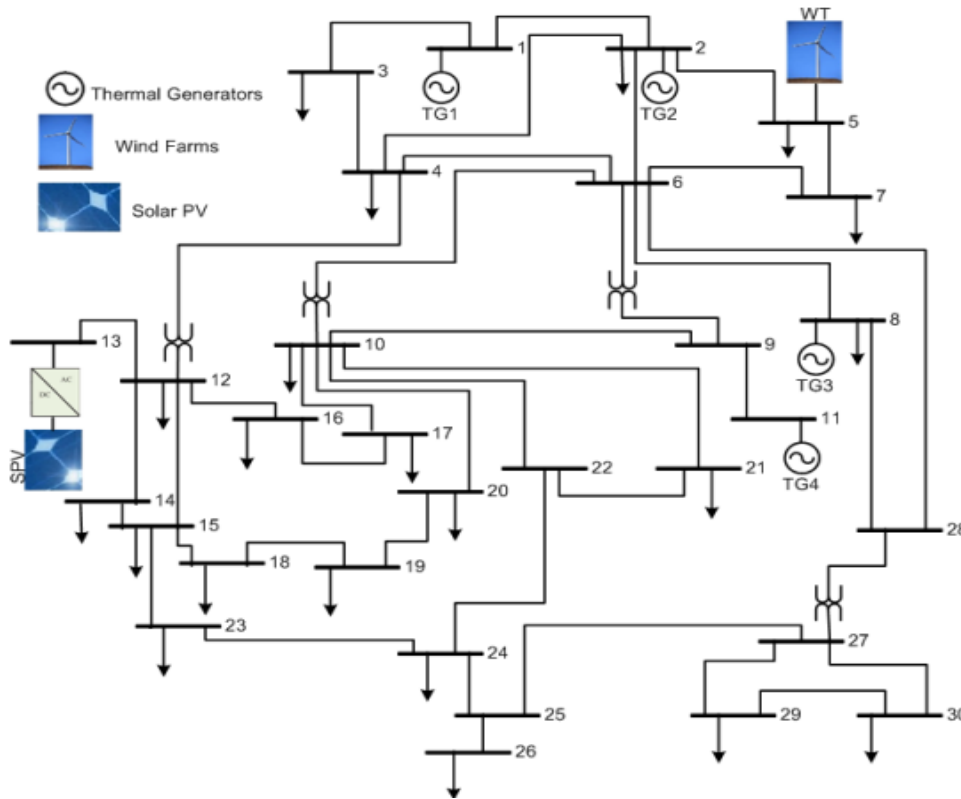

Figure 3: Standard IEEE-30 bus test case with modification. (Riaz et.al., 2021)

## Results

The IEEE 30-bus system data were used to run the load flow analysis. The base case was first evaluated, and then the WDO and IWDO were introduced on the IEEE 30-bus network so as to ascertain the performances of the said meta-heuristic techniques. Subsequently, the two techniques were compared.

**Table 1: Performance evaluation on the IEEE 30-bus network**

PARAMETERS	BASE CASE	WDO	IWDO
DG position and size (MW)	-	5(75) 23(43)	5(75) 28(18)
DG position and size (MVar)	-	5(1) 23 (1)	5 (1) 28 (1)
Total Ploss (MW)	18.902	7.4511	7.3240
Ploss reduction (%)	-	60.58	61.25
Total Qloss (MVar)	73.495	31.866	31.587
Qloss reduction	-	56.64	57.02
Computational time (sec)	1.525	228	230

From the results presented in Table 1 above, the base case was run without the introduction of Renewable energy (wind and solar) which was the type of DG considered. The power losses (both active power losses and reactive power losses) were relatively high but upon introducing wind and solar energy of optimal sizes at relevant buses (buses 5 and 23) the power losses were greatly minimized from 18.9 MW to 7.4MW for WDO and 7.3MW for IWDO while reactive power loss

was reduced from 73.5MVar to 31.9 MVar for WDO and 31.6 MVar for IWDO. Comparisons between WDO and IWDO were successfully evaluated and the IWDO performed better than the WDO in terms of both active and reactive power losses.

Figures 2 and 3 represent the real and reactive power losses of the IEEE 30-bus for the base case and upon introduction of WDO and IWDO.

It can be observed that, there is a significant decrease in the power losses, for example, from line 17, real power loss reduces from 3.2MW to 2MW while in Figure 3 reactive power reduces from 2.4MVar to 1.5 MVar in line 25.

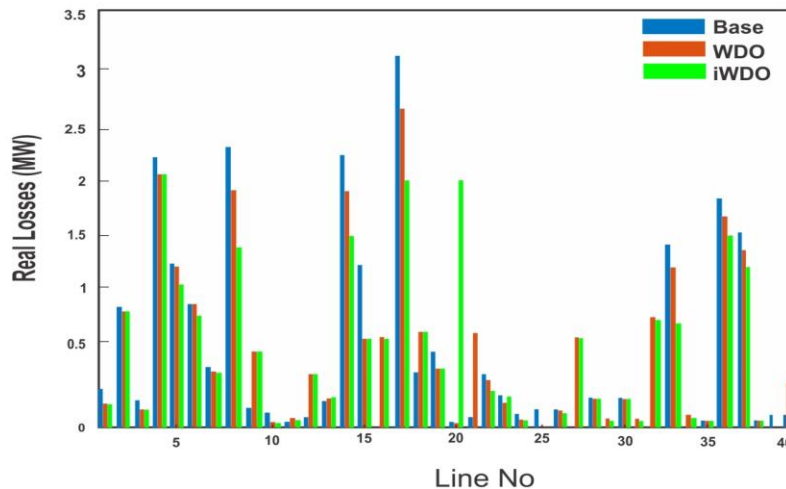

Figure 2 above represents the real power loss for the base case, WDO and the IWDO for the IEEE 30-bus network. It can be seen that at each level of the optimization process the IWDO real power losses bar is below the other two bars meaning that there is always a real power loss reduction using the IWDO algorithm.

Figure 3 below shows the reactive power loss for the base case, WDO and the IWDO for the IEEE 30-bus network

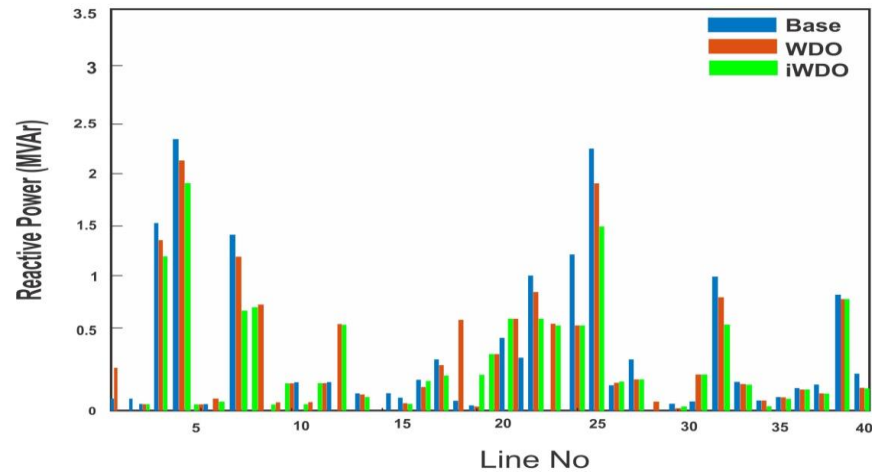
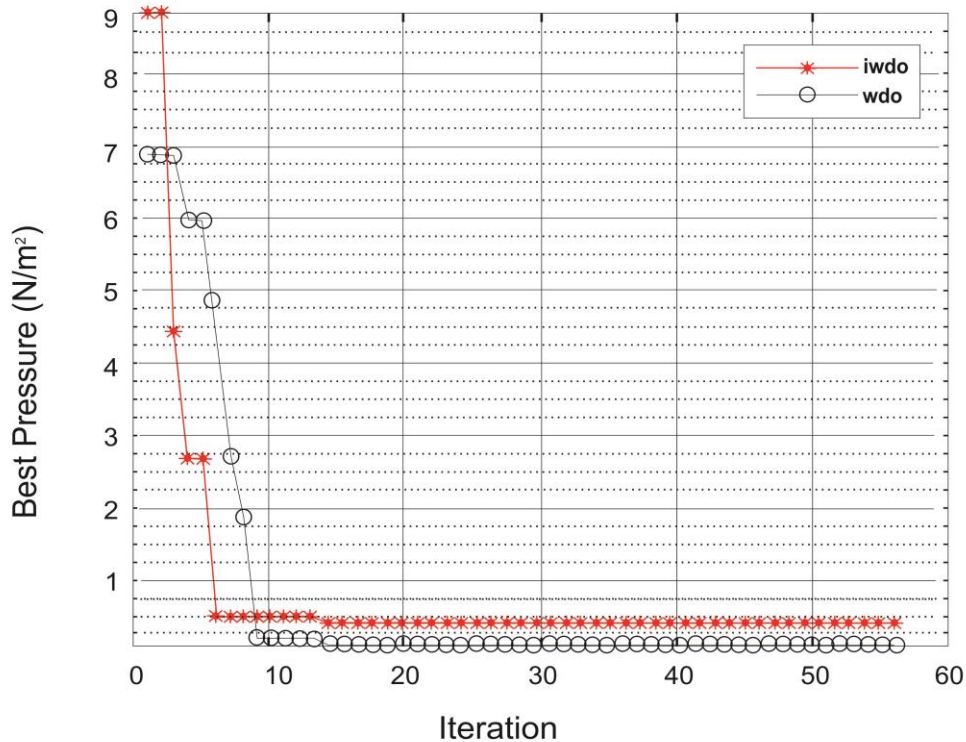

Figure 3: Combined reactive power loss for IEEE 30-bus

### Convergence Characteristics of WDO and IWDO

Comparing the two convergences from Figure 4 below, it can be observed that; the IWDO start to converged fast at the 6<sup>th</sup> iteration while for the WDO starts to converged at the 9<sup>th</sup> iteration, thus giving the IWDO an upper hand as shown below.

It can be seen from the figure that the improved wind driven algorithm converged fast than the wind driven algorithm and arrived at a slightly lower optimal result. This shows the improved wind driven algorithm was able to avoid local minima and arrive at a global minimum.



Figure

8: Combined Convergence graph for WDO and IWDO

Comparing the two convergence graphs on Figure 4, it can be observed that; the rate of convergence of IWDO is faster than the WDO and thus giving the IWDO an upper hand over the WDO.

### Summary and Conclusion

The IWDO algorithm was successfully used on the IEEE-30 bus network system and has yielded optimal results minimizing active power losses and reactive power losses as follows:

- i. A 61.25% loss of real power reduction was achieved after optimally placing and sizing the distributed generation (DG).
- ii. A 57.02% reduction in reactive power loss was achieved upon placing the DG optimally.
- iii. The WDO and IWDO were compared to test for the best alternative which shows that IWDO is better.
- iv. The IWDO performed 0.876% better than the WDO in terms of minimizing power loss with high convergence rate.

Thus, this result show that, applying the IWDO on IEEE 33 bus system and any network such as the Nigerian power system with renewable DGs at optimal positions will go a long way to minimize both technical and financial losses.



## REFERENCES

- Bayraktar, Z., Komurcu, M., & Werner, D. H. (2010, July). Wind Driven Optimization (WDO): A novel nature-inspired optimization algorithm and its application to electromagnetics. In *2010 IEEE antennas and propagation society international symposium* (pp. 1-4). IEEE.
- Boucekara, H. R. E. H., Chaib, A. E., & Abido, M. A. (2016). Multiobjective optimal power flow using a fuzzy based grenade explosion method. *Energy Systems*, 7, 699-721.
- Chamanbaz, M., Dabbene, F., & Lagoa, C. (2017). AC optimal power flow in the presence of renewable sources and uncertain loads. *arXiv preprint arXiv:1702.02967*.
- Farhat, M., Kamel, S., Atallah, A. M., & Khan, B. (2021). Optimal power flow solution based on jellyfish search optimization considering uncertainty of renewable energy sources. *IEEE Access*, 9, 100911-100933.
- Farhat, M., Kamel, S., Atallah, A. M., & Khan, B. (2022). Developing a marine predator algorithm for optimal power flow analysis considering uncertainty of renewable energy sources. *International Transactions on Electrical Energy Systems*, 2022.
- Khamees, A. K., Badra, N., & Abdelaziz, A. Y. (2016). Optimal power flow methods: A comprehensive survey. *International Electrical Engineering Journal (IEEJ)*, 7(4), 2228-2239.
- Khamees, A. K., El-Rafei, A., Badra, N. M., & Abdelaziz, A. Y. (2017). Solution of optimal power flow using evolutionary-based algorithms. *International Journal of Engineering, Science and Technology*, 9(1), 55-68.
- Khamees, A. K., Abdelaziz, A. Y., Eskaros, M. R., Attia, M. A., & Sameh, M. A. (2022). Optimal power flow with stochastic renewable energy using three mixture component distribution functions. *Sustainability*, 15(1), 334.
- Liu, Y., Zhang, S., Jiang, Y., Wang, D., Gu, Q., & Zhang, Z. (2021). Improved wind driven optimization algorithm for the optimization of hydropower generation from a reservoir. *Journal of Hydroinformatics*, 23(6), 1197-1213.
- Reddy, S. S., Bijwe, P. R., & Abhyankar, A. R. (2014). Real-time economic dispatch considering renewable power generation variability and uncertainty over scheduling period. *IEEE Systems journal*, 9(4), 1440-1451.

- Riaz, M., Hanif, A., Masood, H., Khan, M. A., Afaq, K., Kang, B. G., & Nam, Y. (2021). An optimal power flow solution of a system integrated with renewable sources using a hybrid optimizer. *Sustainability*, *13*(23), 13382.
- Shaheen, M. A., Hasanien, H. M., Turky, R. A., Calasan, M., Zobaa, A. F., & Abdel Aleem, S. H. (2021). Opf of modern power systems comprising renewable energy sources using improved chgs optimization algorithm. *Energies*, *14*(21), 6962.
- Shaheen, M. A., Ullah, Z., Qais, M. H., Hasanien, H. M., Chua, K. J., Tostado-Véliz, M., ... & Elkadeem, M. R. (2022). Solution of probabilistic optimal power flow incorporating renewable energy uncertainty using a novel circle search algorithm. *Energies*, *15*(21), 8303.
- Zhou, W., Peng, Y., & Sun, H. (2011). Optimal wind–thermal coordination dispatch based on risk reserve constraints. *European Transactions on Electrical Power*, *21*(1), 740-756.
- Zhou, Y., Bao, Z., Wang, R., Qiao, S., & Zhou, Y. (2015). Quantum wind driven optimization for unmanned combat air vehicle path planning. *Applied sciences*, *5*(4), 1457-1483.
- Balasubbareddy, M. (2022). Optimal power flow solution using ameliorated ant lion optimization algorithm. *International Journal of Mechanical Engineering*, *13*(1), 1060.